

### Main features

- Protection degrees IP67 and IP69K
- Stainless steel captive screws
- 4 side cable entries
- Screw caps included in the scope of supply

### Quality marks:



EAC approval: RU C-IT.AD35.B.00454

### Technical data

#### Housing

Material:

Self-extinguishing shock-proof polycarbonate with double insulation, UV-resistant and glass fibre reinforced, high shock resistance.

Material of the screws:

Stainless steel

Conduit entries:

4x knock-out side entries:  
N°2 M20 - 1/2 NPT, N°2 M20 - 1/2NPT - M25  
2x M16 knock-out base entries

Emergency button

Mechanical endurance:

300,000 operating cycles

Max. actuation frequency:

3600 operating cycles/hour

Actuation travel:

4 mm (NO contact),  
4 mm (NC contact)

Actuating force:

25 N

Actuating force at limit of travel:

Push-pull 18.5 N (without contacts)  
Rotary release, 35 N (without contacts)

Maximum travel:

9 mm

Tightening torque of the fixing ring:

2 ... 2.5 Nm

### General data

Protection degree:

IP67 acc. to EN 60529, (with cable gland of equal or higher protection degree)

IP69K acc. to ISO 20653

(only for versions without luminous disc)

Ambient temperature:

-25°C +80°C

Tightening torque of the cover screws:

1 ... 1.4 Nm

Utilization requirements:

see page 139 of the General Catalogue HMI 2017-2018.

### In compliance with standards:

IEC 60947-1, IEC 60947-5-1, IEC 60204-1, EN 60947-1, EN 60947-5-1, EN 60204-1, EN ISO 13850, UL 508, CSA 22-2 N°14.

### Compliance with the requirements of:

Machinery Directive 2006/42/EC

### General data

#### Protection degrees IP67 and IP69K

IP69K  
IP67

These devices are designed to be used in the toughest environmental conditions and they pass the IP67 immersion test acc. to EN 60529. They can therefore be used in all environments where maximum protection degree of the housing is required. Due to their special design,

these devices are suitable for use in equipment subjected to cleaning with high pressure hot water jets. These devices meet the IP69K test requirements according to ISO 20653 (water jets with 100 bar and 80°C).

#### Fixing of EROUND housings

The new housings of the EROUND line by Pizzato Elettrica have 4 additional holes on the cover. The holes enable wall fixing from the outside by means of insertion of the screws, without the need to open the cover to access the holes.

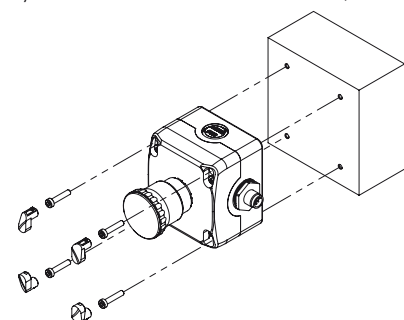

The wall fixing screws and the ones for closing the housing cover can be sealed with 4 caps (supplied with the housing). The caps not only give the housing a more pleasant look, but they also prevent the accumulation of dirt inside the recesses of the screws besides making tampering more difficult.

The external fixing of the housing is particularly valuable for already wired housings, since this simplifies the whole installation: you can simply fix the housing and connect the connector that, thanks to the presence of cable entries on the four sides of the housing, can be oriented in the preferred direction.

#### One housing, two solutions

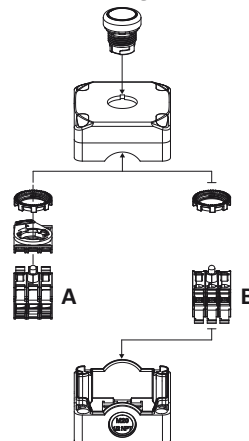

The housing can fit up to 3 contact blocks/LED units (E2 CP, E2 LP) for panel mounting by means of a mounting adapter (A) or up to 3 contact blocks/LED units (E2 CF, E2 LF) for base mounting directly on the bottom of the housing (B).

#### Wiring through the lower surface

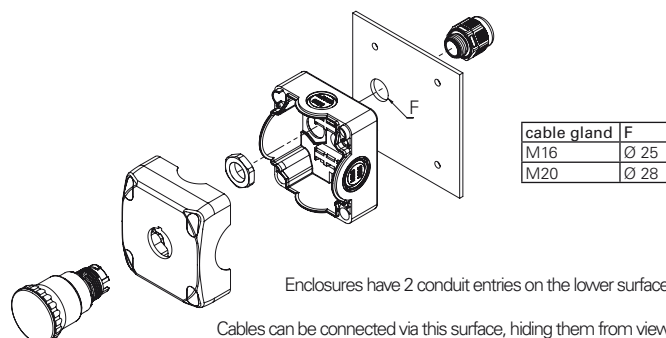



## Complete units with housing with emergency buttons



Housing cover colour	Actuator design and colour	Contacts			Emergency button Push-Pull	Emergency button Rotary release	Emergency button key release
		pos. 2	pos. 3	pos. 1			
yellow RAL 1003	red	-	1NC	-	<b>ES AC31004</b> ES 31001 + E2 1PEPZ4531 + E2 CF01G2V1	<b>ES AC31003</b> ES 31001 + E2 1PERZ4531 + E2 CF01G2V1	<b>ES AC31022</b> ES 31001+ E2 1PEBZ4531 + E2 CF01G2V1
yellow RAL 1003	red	-	1NC SELF-MONITORED	-	<b>ES AC31081</b> ES 31001 + E2 1PEPZ4531 + E2 CF01S2V1	<b>ES AC31082</b> ES 31001 + E2 1PERZ4531 + E2 CF01S2V1	<b>ES AC31083</b> ES 31001+ E2 1PEBZ4531 + E2 CF01S2V1
yellow RAL 1003	red	1NC	-	1NC	<b>ES AC31009</b> ES 31001 + E2 1PEPZ4531 + E2 CF01G2V1	<b>ES AC31005</b> ES 31001 + E2 1PERZ4531 + E2 CF01G2V1	<b>ES AC31023</b> ES 31001+ E2 1PEBZ4531 + E2 CF01G2V1
yellow RAL 1003	red	1NC	-	1NO	<b>ES AC31010</b> ES 31001 + E2 1PEPZ4531 + E2 CF01G2V1 + E2 CF10G2V1	<b>ES AC31006</b> ES 31001 + E2 1PERZ4531 + E2 CF01G2V1 + E2 CF10G2V1	<b>ES AC31011</b> ES 31001+ E2 1PEBZ4531 + E2 CF01G2V1 + E2 CF10G2V1
yellow RAL 1003	red	1NC	1NC	1NO	<b>ES AC31146</b> ES 31001 + E2 1PEPZ4531 + E2 CF01G2V1 + E2 CF01G2V1 + E2 CF10G2V1	<b>ES AC31021</b> ES 31001 + E2 1PERZ4531 + E2 CF01G2V1 + E2 CF10G2V1	<b>ES AC31024</b> ES 31001+ E2 1PEBZ4531 + E2 CF01G2V1 + E2 CF01G2V1 + E2 CF10G2V1

Other combinations on request.  
The standard colour of the base for the codes mentioned above is RAL 9005.  
For properties of contact blocks, see the General Catalogue HMI.



Housing cover colour	Actuator design and colour	Contacts			Emergency button Push-Pull Yellow luminous disc, flashing Ø 60 mm, 24 Vac/dc	Emergency button rotary release Yellow luminous disc, flashing Ø 60 mm, 24 Vac/dc	Emergency button key release Yellow luminous disc, flashing Ø 60 mm, 24 Vac/dc
		pos. 2	pos. 3	pos. 1			
grey RAL 7035	red	1NO	1NC	CONNECTION BLOCK	<b>ES AC31430</b> ES 31000 + E2 1PEPZ4531 + VE DL1A5L13 + E2 CP10G2V1 + E2 CP01G2V1 + VE BC2PV1	<b>ES AC31433</b> ES 31000 + E2 1PERZ4531 + VE DL1A5L13 + E2 CP10G2V1 + E2 CP01G2V1 + VE BC2PV1	<b>ES AC31436</b> ES 31000 + E2 1PEBZ4531 + VE DL1A5L13 + E2 CP10G2V1 + E2 CP01G2V1 + VE BC2PV1
grey RAL 7035	red	1NO	1NC SELF-MONITORED	CONNECTION BLOCK	<b>ES AC31431</b> ES 31000 + E2 1PEPZ4531 + VE DL1A5L13 + E2 CP10G2V1 + E2 CP01S2V1 + VE BC2PV1	<b>ES AC31434</b> ES 31000 + E2 1PERZ4531 + VE DL1A5L13 + E2 CP10G2V1 + E2 CP01S2V1 + VE BC2PV1	<b>ES AC31437</b> ES 31000 + E2 1PEBZ4531 + VE DL1A5L13 + E2 CP10G2V1 + E2 CP01S2V1 + VE BC2PV1
grey RAL 7035	red	1NO	2NC	CONNECTION BLOCK	<b>ES AC31432</b> ES 31000 + E2 1PEPZ4531 + VE DL1A5L13 + E2 CP10G2V1 + E2 CP02G2V1 + VE BC2PV1	<b>ES AC31435</b> ES 31000 + E2 1PERZ4531 + VE DL1A5L13 + E2 CP10G2V1 + E2 CP02G2V1 + VE BC2PV1	<b>ES AC31438</b> ES 31000 + E2 1PEBZ4531 + VE DL1A5L13 + E2 CP10G2V1 + E2 CP02G2V1 + VE BC2PV1

Other combinations on request.  
The standard colour of the base for the codes mentioned above is RAL 9005.  
→ For the properties of contact blocks and luminous discs, please see the General Catalogue HMI.

### Spare caps

Article	Description
 VETS35RA1	4 spare caps for ES series housing cover. Colour: yellow
 VETS39RA1	4 spare caps for ES series housing cover. Colour: grey

### Dimensions

All values in the drawings are in mm

